

b.Alert fuel manual



1. INTRODUCTION

Thank you for purchasing a b.Alert system.

You now possess a superior unit not only to trace your fleet, but especially a system that will protect your trailers and your goods in the trailers against theft, protect against fuel theft, follow the tires, This manual explains the installation possibilities and the usage of the b.Alert products and services.

The communication with the units goes through a website. This manual explains the functionality of the site and the units. We aimed at creating a site that is as user friendly and as self explaining as possible.

2. TABLE OF CONTENTS

1.	introduction	2
2.	table of contents	3
3.	functionalities and characteristics	5
4.	use of batteries	6
5.	b.Alert Fuel V2.....	7
5.1.	installation	7
5.2.	electrical connections.....	8
5.3.	electrical characteristics of the connections	12
5.4.	B.Alert fuel V2 utilization.....	13
5.5.	b.Alert fuel V2 on the platform	13
6.	website and login	14
6.1.	login	14
6.2.	screen lay-out	15
6.2.1.	main menu	16
6.2.2.	map	17
6.2.3.	lists	18
6.2.4.	tabs.....	19
6.2.5.	pictures.....	20
6.3.	online analyzing data	23
6.3.1.	the history of a unit.....	26
6.4.	alarms	30
6.4.1.	no power	30
6.4.2.	battery low	31
6.4.3.	fuel alarm	32
6.5.	preferences.....	33
6.5.1.	User info.....	33
6.5.2.	Website preferences	35

6.5.3. device groups	36
6.5.4. Devices	37
6.5.5. limited users.....	38
6.5.6. mailing of reports	39
7. figures and tables.....	40
copyright notice	42
preliminary notice.....	42
Regulations.....	43
battery disposal.....	43
High Risk Materials.....	43
Environmental Information for Customers in the European Union.....	43
Limited product warranty	44
General terms	44
Countries in which this B.ALERT Limited Product Warranty applies.....	44
Limitation of product warranty.....	44
Limited product warranty period.....	45
Limited product warranty period.....	45
Warrantor	45
Safety instructions	46
Power Sources.....	46
Battery.....	47
Servicing and Disassembling	47
Environment.....	47
Cleaning.....	48

3. FUNCTIONALITIES AND CHARACTERISTICS

- Protection against fuel theft on trucks, construction machines, agricultural machines and fuel tanks
- Determination of theft based on vibration detection
- 1 main unit and maximum 6 sensors for fuel tanks and other parts to protect
- Local alarm in 2 phases
- Silent alarm : User interface through web. For the different setup and functions see the relevant paragraphs in the manual
- –
- Deactivation through a button for the driver/operatr
- Silent alarm of “activity” during deactivation
- Internal LiPo battery
 - Needs to be connected to a DC power source 10-30V
 - Autonomy 1 hour when power cable has been cut

4. USE OF BATTERIES

For the b.Alert units with a rechargeable battery, it is advised that the battery is always kept fully charged.

The unit has an internal trickle charging circuit to charge.

Never leave a unit with an uncharged battery for more than 2 weeks. If this happens, the capacity of the battery (hence the autonomy) can be reduced.

To keep the internal batteries always charged at full capacity, a charging time of 12 hours/week is needed. If this is not possible, please contact b.Alert for a solution.

5. B.ALERT FUEL V2

5.1. INSTALLATION

The unit consists of 2 or more elements:

- A main unit
- One or more sensors

The main units has to be fixed with a nut on the chassis, as close as possible to the point where the fuel tanks are fixed to the chassis.

The sensors are connected to the main unit with a cable, one after the other. They are foreseen with a metal ring and need to be fixed to the neck of the fuel tank as rigidly as possible. This is shown on Figure 1.

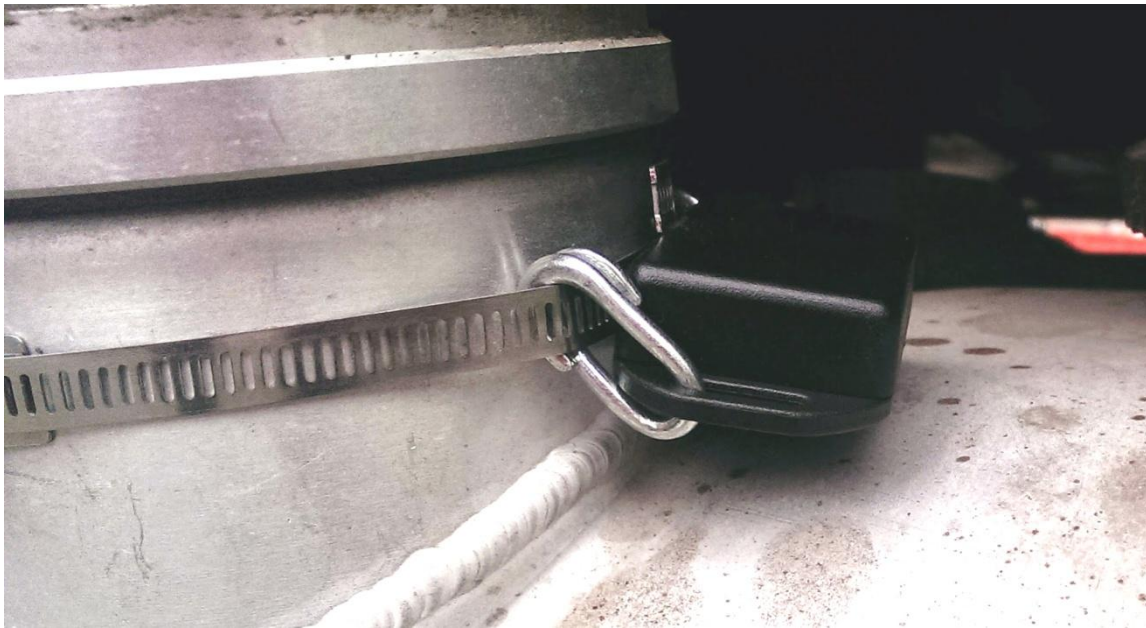

Figure 1 b.Alert Fuel v2 sensor installed on tank

5.2. ELECTRICAL CONNECTIONS

The electrical connections need to be made on the main unit. There is a small cable glant for the power connection and a wide cable glant for the connections to the different alarms.

Be careful to close the cable glants after putting the cables through with enough strength that they are closed perfectly around the cables. This is necessary to keep the unit water tight.

To make the connections, open the main unit carefully by unscrewing the 4 top screws.

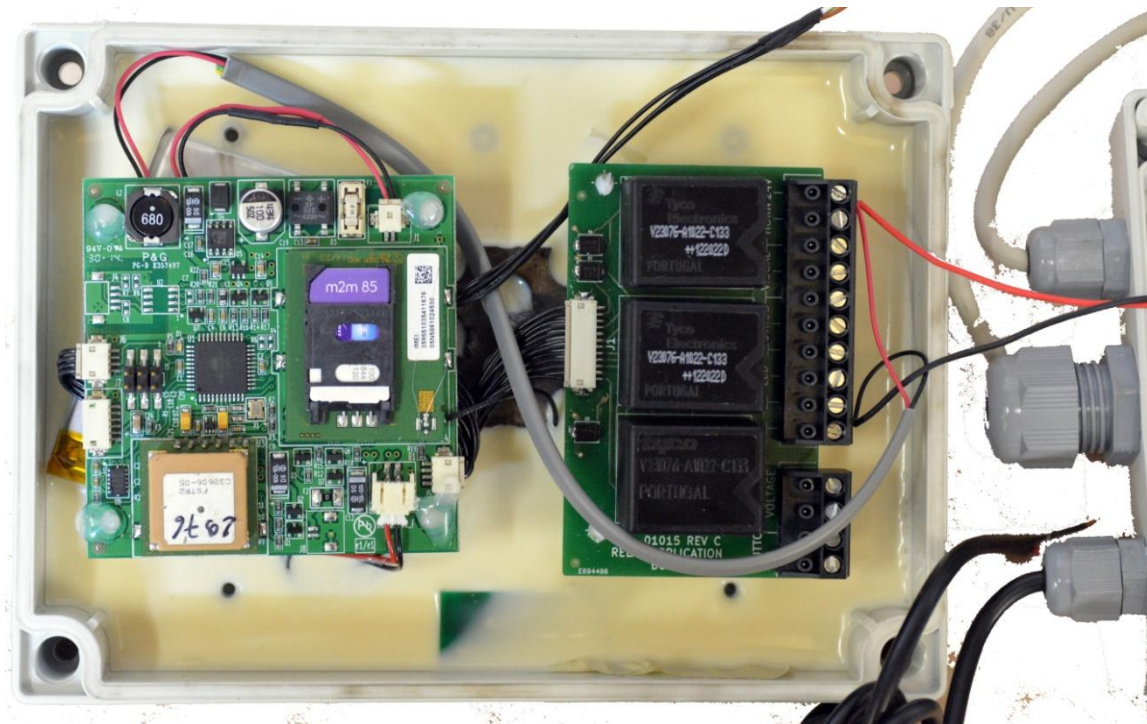

Figure 2 inside of main unit

All cables need to be connected to the screw connectors as shown on Figure 3 and Figure 4.

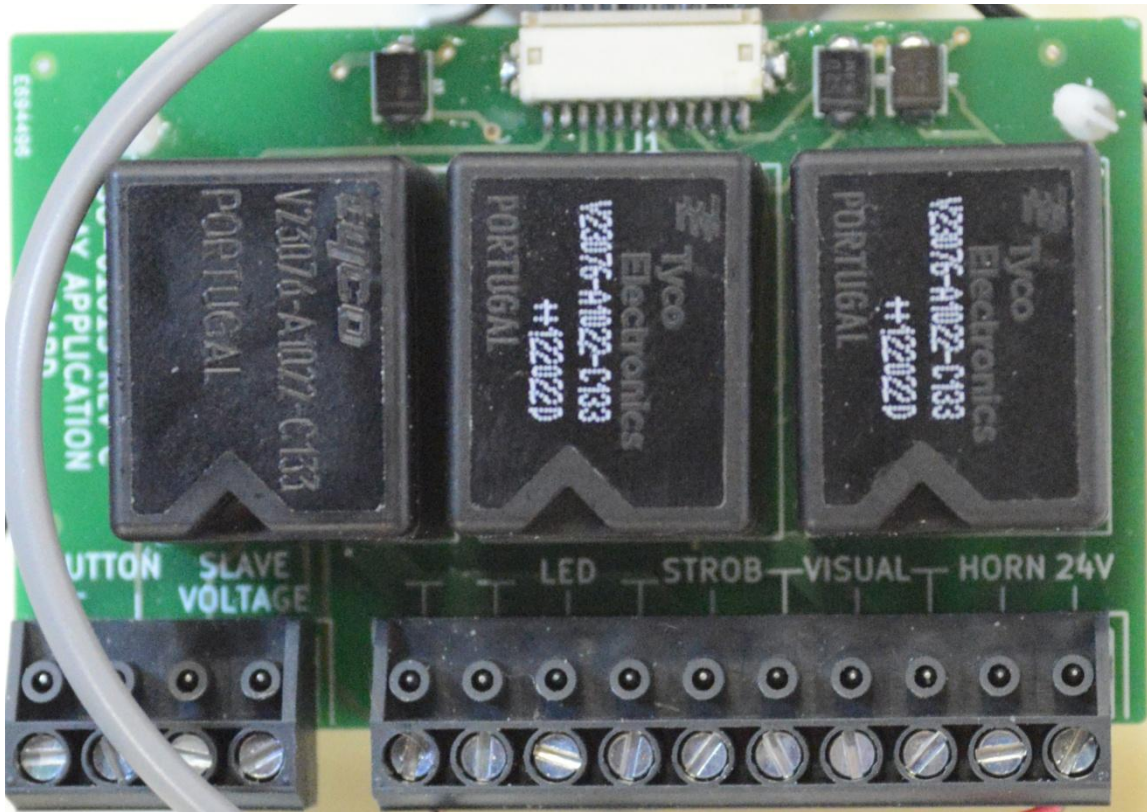

Figure 3 cable connections on main unit

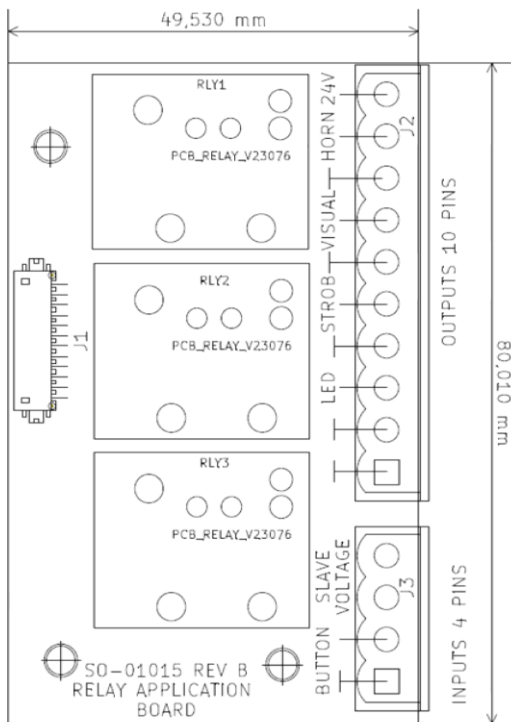

Figure 4 cable connections main unit : scheme

On the pcb lay-out, the names of the connections are printed. For every function, there is a positive connector and a (negative) mass. All mass connections are connected to each other. In this way, it is possible to connect a double wire (positive and negative) or only a single positive cable and to connect the mass to a mass point on the truck.

The electrical power connection is connected to the positive power 24V and to the negative or the mass on the other side of the connector. The connection needs to be powered continuously to keep the unit activated. When the power is disconnected or lost, a phase 2 alarm will be given. The power consumption has a maximum charge of 12 A.

The signal cables need to be connected to lights and horn to produce the alerts in case of an event. A relay is not necessary, these are already present in the main unit as can be seen on Figure 3. The correct port numbers are given on Figure 4.

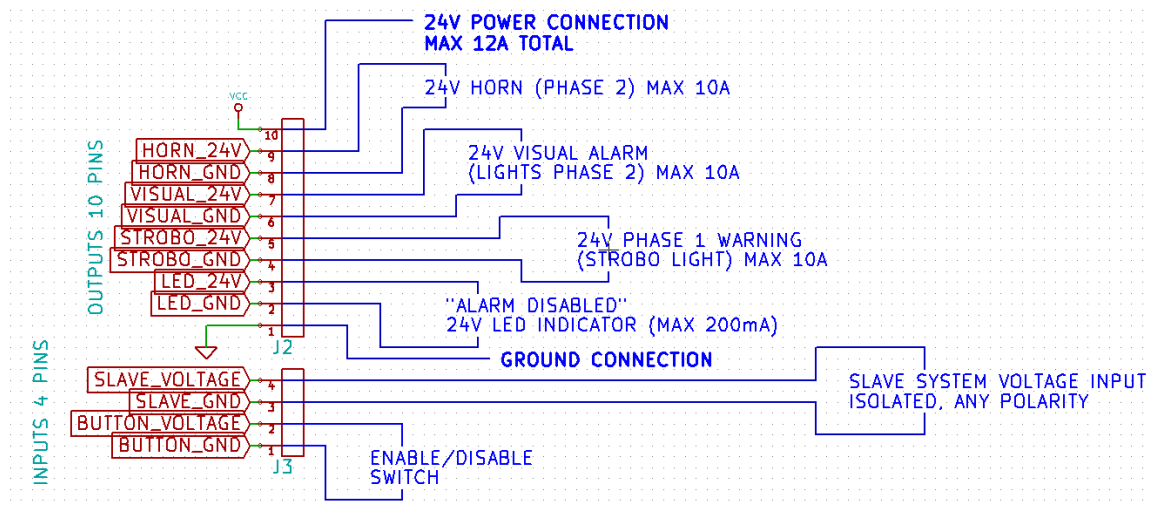

Figure 5 electrical connections b.Alert Fuel V2

The alerts are given in 2 phases.

- Phase 1 is given to show the thief that he has been detected. It can be connected to a working light nearby the tank, stroboscope LED's, Also, when somebody touches the tank by accident, he will be warned, without the alarm alerting everybody. This is connector **STROB**.
- Phase 2 alert should be connected to the lights of the truck and the horn. When a thief continues to steal, an audible signal is needed. The connections are **VISUAL** and **HORN**. **REMARK THAT ON THE PCB THE NAMES HAVE BEEN PRINTED WRONGLY. THE HORN NEEDS TO BE CONNECTED TO THE WORD "VISUAL" AND THE VISUAL TO THE WORD "HORN"**.

The alert can be de-activated by a button to be placed in the cabin. In that button, a (red) LED shows that the unit has been deactivated. The button should be a push button as the unit re-activates itself when the user forgets to re-activate the unit.

The connections for the button are

- **BUTTON** on the small connector fo the button itself
- **LED** for the indicator LED in or near the button

5.3. ELECTRICAL CHARACTERISTICS OF THE CONNECTIONS

The specification for the power is 10 – 30 V DC. With a fully charged internal battery, the unit consumes a maximum of 0.01 A. the maximum current consumption with an empty internal battery at 24V is 150 mA. With a fully charged internal battery, the unit consumes a maximum of 0.01 A. the maximum current consumption with an empty internal battery at 24V is 150 mA.

The unit has maximum 6 connections: 2 inputs and 4 outputs. They have following electronic characteristics and functionality.

For the outputs, there are 2 types present: normally open and normally closed.

The characteristics and functionality of the b.Alert Plus outputs and inputs is given by

- 2 x Input connections : Bidirectional optically isolated inputs : max 30V continuous (both polarities supported) : Input voltage determines the logical value of the input
 - voltage between the 2 pins of the input > 3V = input logical ON state
 - voltage between the 2 pins of the input < 1V = input logical OFF state
- 1 x Output connections : OptoMos Relay : works like a switch
 - specs: max 250mA, max 30V continuous (both polarities supported)
 - connection LED
- 3 x output connection : relay :
 - specs: max 10A, max 30V continuous (both polarities supported)
 - horn is normally open type, the others are normally closed.

5.4. B.ALERT FUEL V2 UTILIZATION

b.Alert fuel works fully automated. The alerts are created the moment an important vibration is given on the fuel tank, for instance by opening the lid or by drilling a hole.

The advanced version will also send a silent alert.

There is only 1 manipulation for the driver:



- **When refilling the tank, when maintaining the truck or when loading or unloading the trailer/truck, the alarm has to be de-activated by pushing the button in the cabin.** At this moment the led on the button will light up and the alarm will not activate.
- Re-pushing the button will re-activate the alarm. When the driver forgets to re-activate the alarm, it is re-activated automatically when he drives again.

The same button is used to stop an alarm situation.

When the unit is de-activated, there will be no alarm signals, except a silent alarm that is sent to the platform. The operator can check if the alarm was on on a site where it is logical and allowed to deactivate the alarm.

5.5. B.ALERT FUEL V2 ON THE PLATFORM

A silent alarm is generated for phase 2 and is indicated on the screen with following symbols.

- Fuel alert: 
- Fuel alert with the de-activation button pressed, i.e. only a silent alert: 

The details are given in **Error! Reference source not found.** on page **Error! Bookmark not defined..**

A special fuel report is created with the dates and the addresses for all alerts. Details are given in **Error! Reference source not found.** on page **Error! Bookmark not defined..**

6. WEBSITE AND LOGIN

6.1. LOGIN

The information concerning the units and the setup can be found on a web site

<https://connect.balert.net>.

Every client gets a unique login. All units are connected to this login. A unit cannot be connected to more than 1 login.

It is however possible to login on the site with the same login from different terminals.

The login name and password are case sensitive.

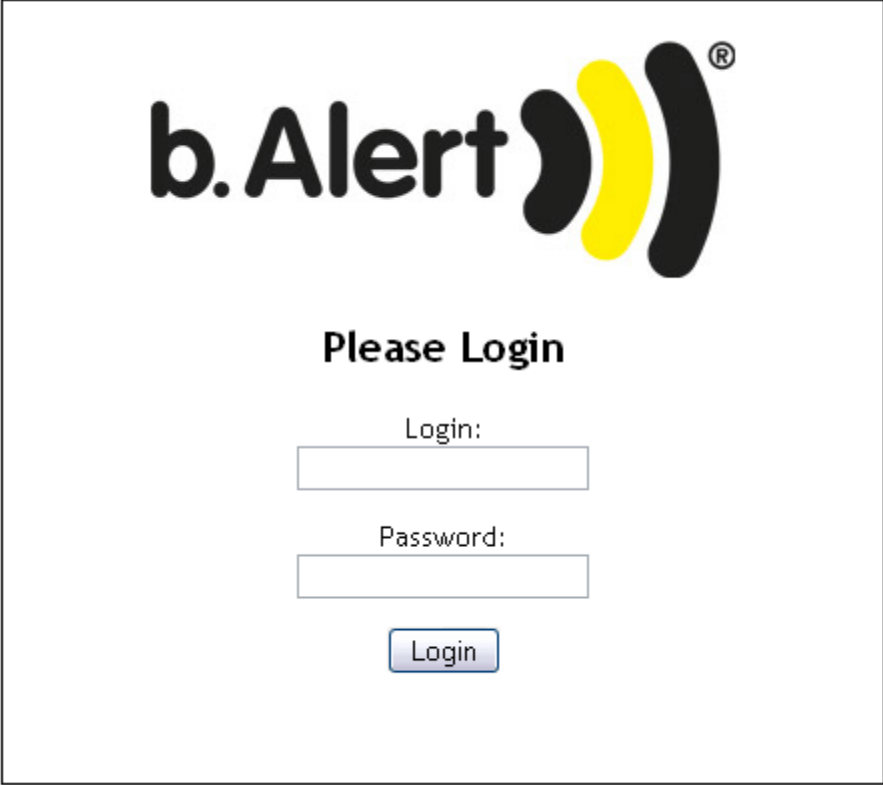

b.Alert 

Please Login

Login:

Password:

Login

Figure 6 login screen

6.2. SCREEN LAY-OUT

Once logged in, one arrives at the mapping screen with a view of all active units.

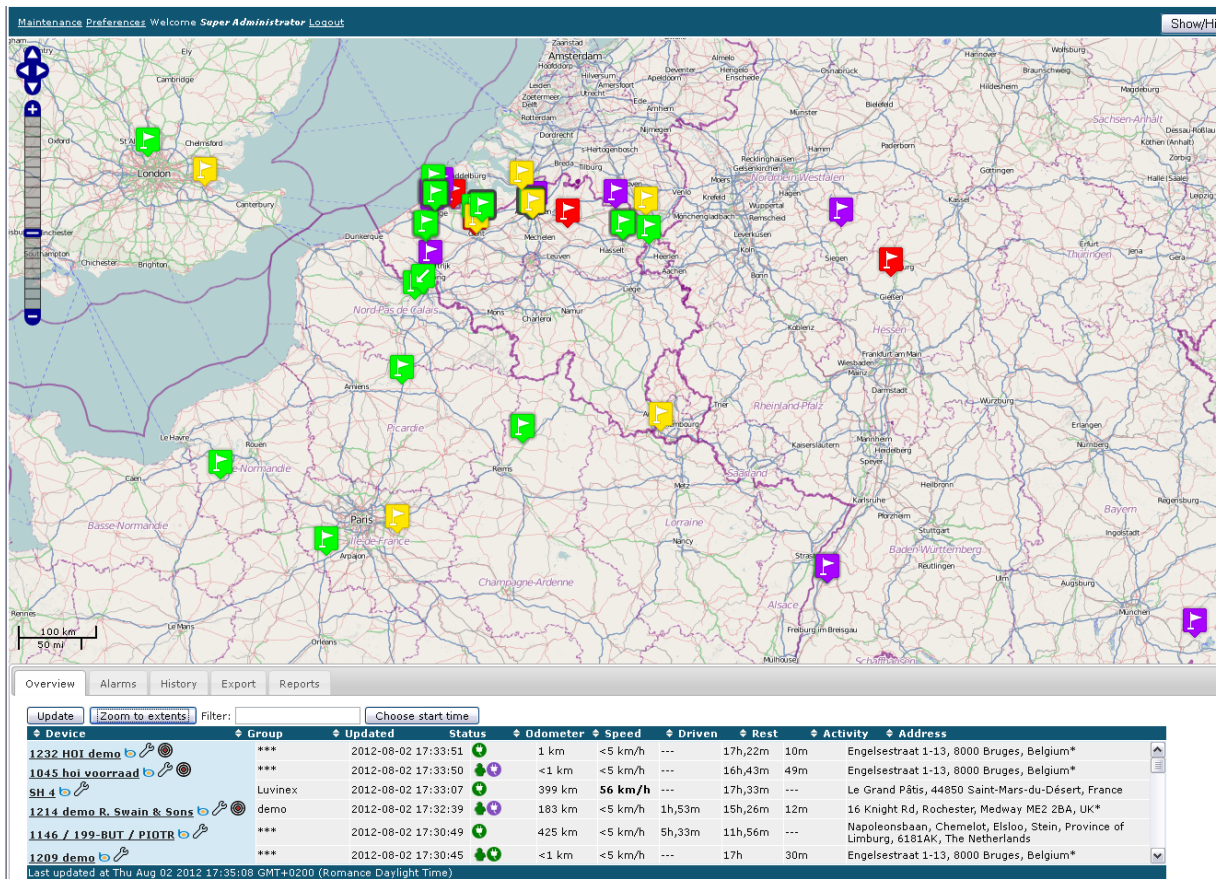

Figure 7 basic screen

This screen consists of 4 parts.

6.2.1. MAIN MENU



Figure 8 settings

Logout : leave the site.

Preferences give you a menu for setup as is explained in 6.5.

Maintenance gives you the possibility to plan the maintenance of the trailers in an efficient way. It is described in **Error! Reference source not found.**

With the button Show/Hide Map it is possible to see a table and a map with the units or only the table.

6.2.2. MAP

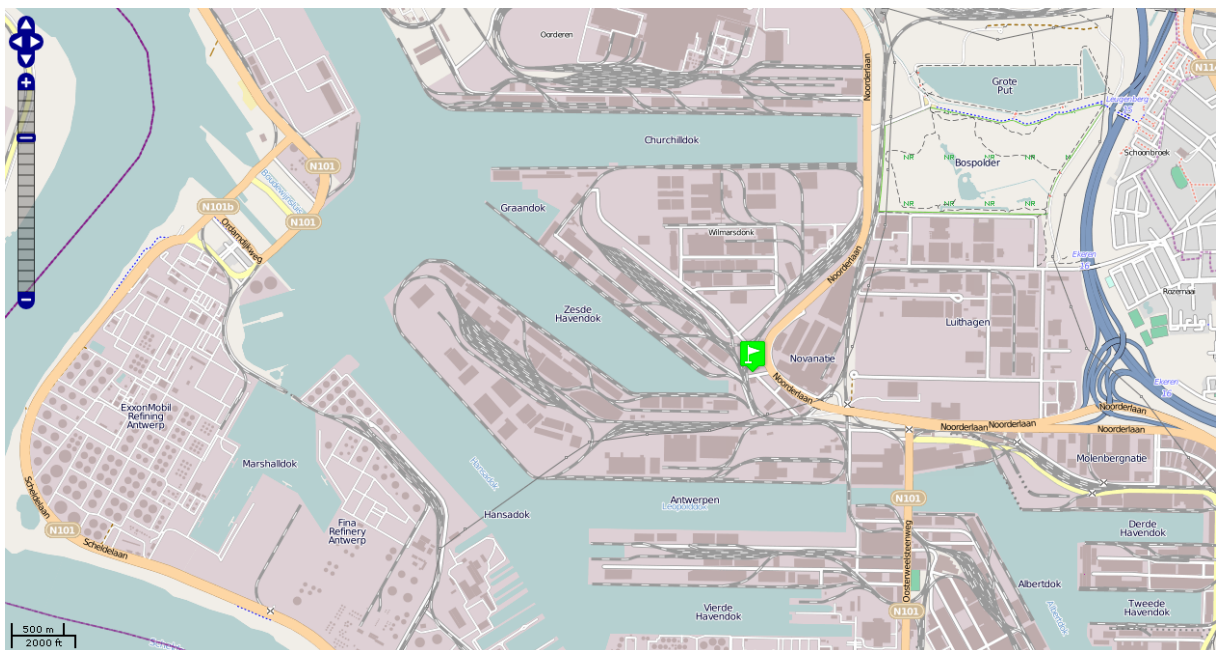
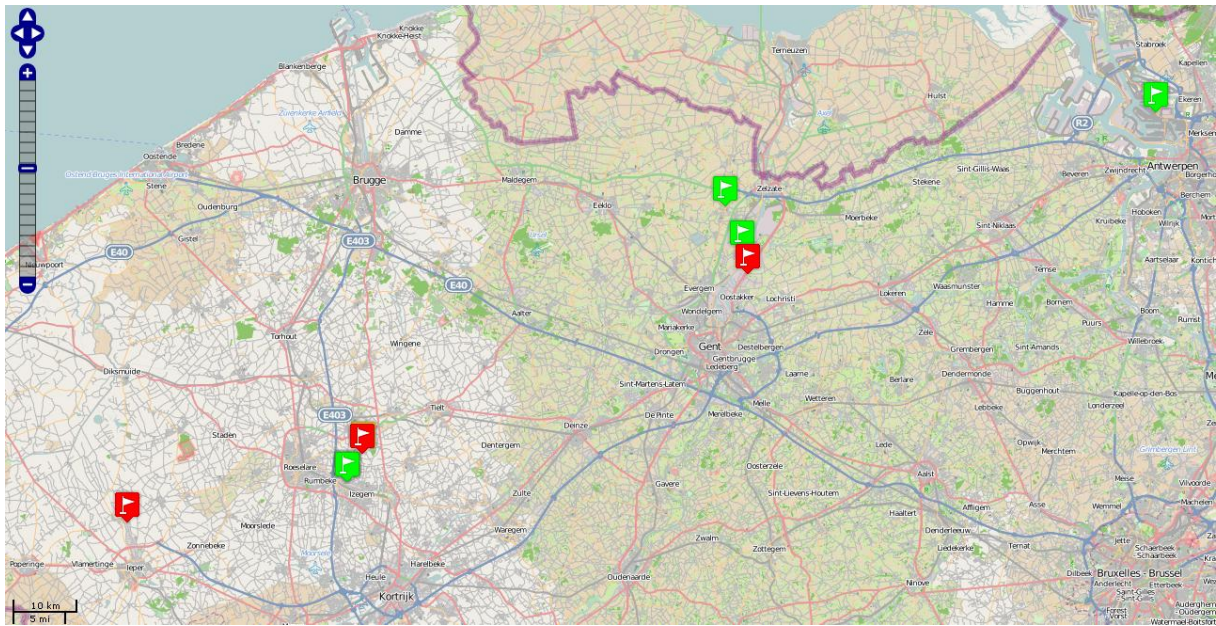

Figure 9 map

The map gives the position of the different units.

It is possible to zoom in details or move the map around. The flags give the positions of the trailers. The colors are explained further in the text and define the status of the trailers.

6.2.3. LISTS

Device	Group	Updated	Status	Odometer	Speed	Driven	Rest	Activity	Address
1045 hoi voorraad	***	2012-08-02 17:40:16		<1 km	<5 km/h	---	16h,43m	56m	Engelsestraat 1-13, 8000 Bruges, Belgium*
1218 Klaus Kienzle	demo	2012-08-02 17:40:04		<1 km	<5 km/h	---	17h,40m	---	*Haldestraße 10, 77933 Lahr, Germany*
SH 2	Luvinox	2012-08-02 17:39:54		599 km	<5 km/h	---	17h,35m	4m	Via Cuneo, Mondovì00ec, CN, PIE, Italy
1232 HOI demo	***	2012-08-02 17:38:47		1 km	<5 km/h	---	17h,26m	11m	Engelsestraat 1-13, 8000 Bruges, Belgium*
1214 demo R. Swain & Sons	demo	2012-08-02 17:37:25		183 km	<5 km/h	1h,53m	15h,26m	17m	16 Knight Rd, Rochester, Medway ME2 2BA, UK*
1146 / 199-BUT / PIOTR	***	2012-08-02 17:35:49		425 km	<5 km/h	5h,33m	12h,1m	---	Napoleonsbaan, Chemelot, Elsloo, Stein, Province of Limburg, 6181AK, The Netherlands*

Last updated at Thu Aug 02 2012 17:43:10 GMT+0200 (Romance Daylight Time)

Figure 10 lists

In the list, all active units are shown with the date of their last signal, their status, their speed and distance driven this day and current address.

By clicking on top of the column it is possible to sort the list according to that column ascending or descending.

The *update* button updates the status of all units, although this also happens automatically in a fixed time interval. This interval can be setup in the preferences.

With *zoom to extents*, it is possible to zoom the map in 1 moment to the extents where all units are.

The filter *filters* the list and the flags on the map so that only those with the letters typed in the field remain. The filter works on all fields in the table, not only the name or the group.

In the table some information is given about the past activities. "Choose the start time", gives you the possibility to change the begin point for the distance or the time or ...



Figure 11 Choose start time

6.2.4. TABS

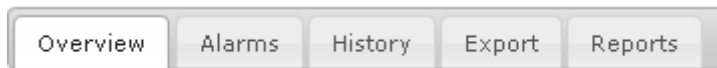

Figure 12 tabs

6.2.5. PICTURES

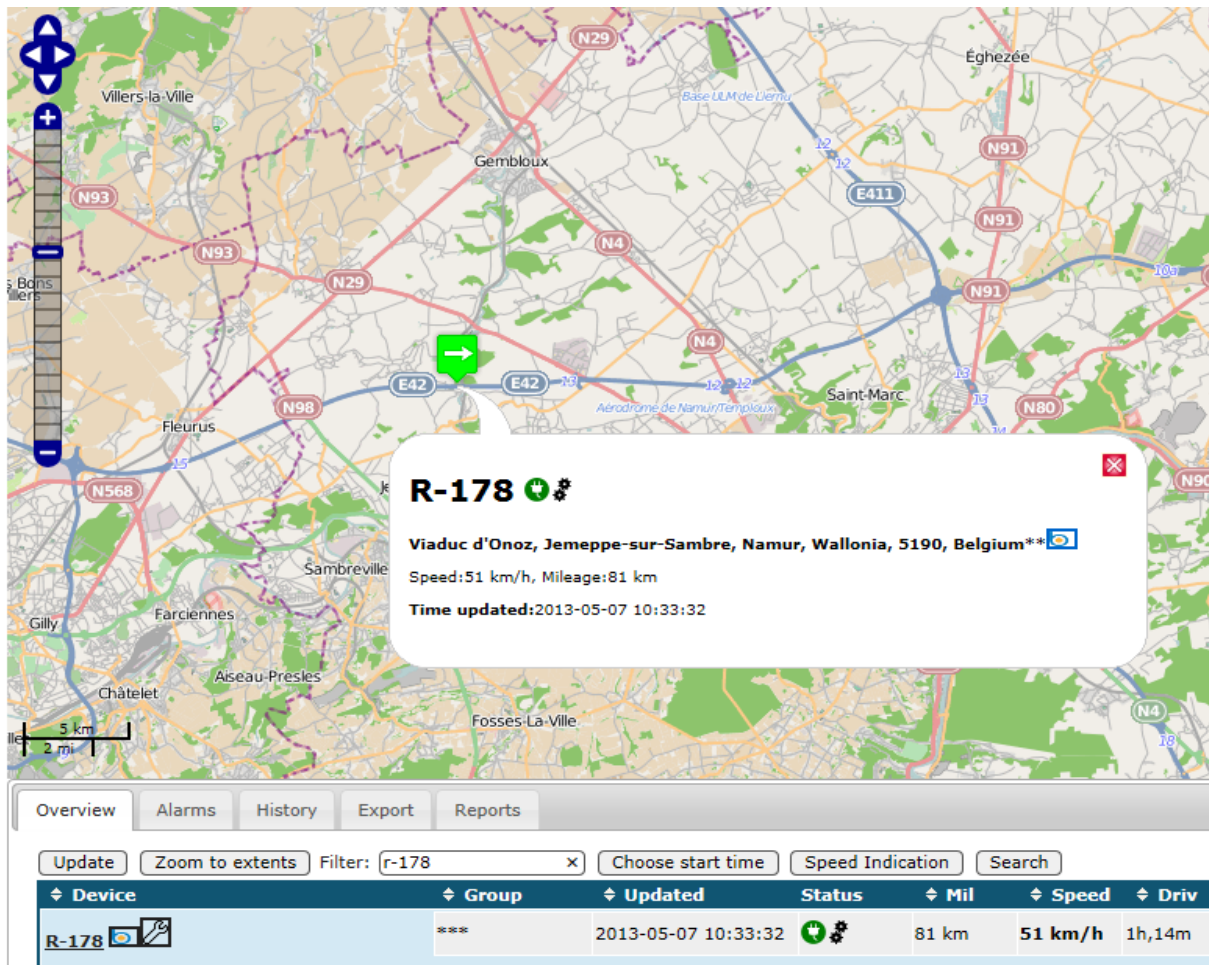

Figure 13 unit to demonstrate Bing

In the table and in the balloon, there is the icon of bing ¹. When clicking on this icon, you will arrive on the website with the aerial picture of bing, centered around the unit.

¹ Bing is a registered trade mark of Microsoft Inc.



Figure 14 aerial map of bing

Where this is possible, bing offers also a bird's eye view.

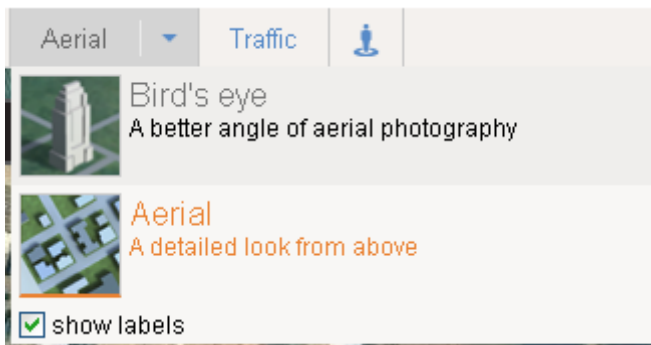

Figure 15 choose bird's eye view

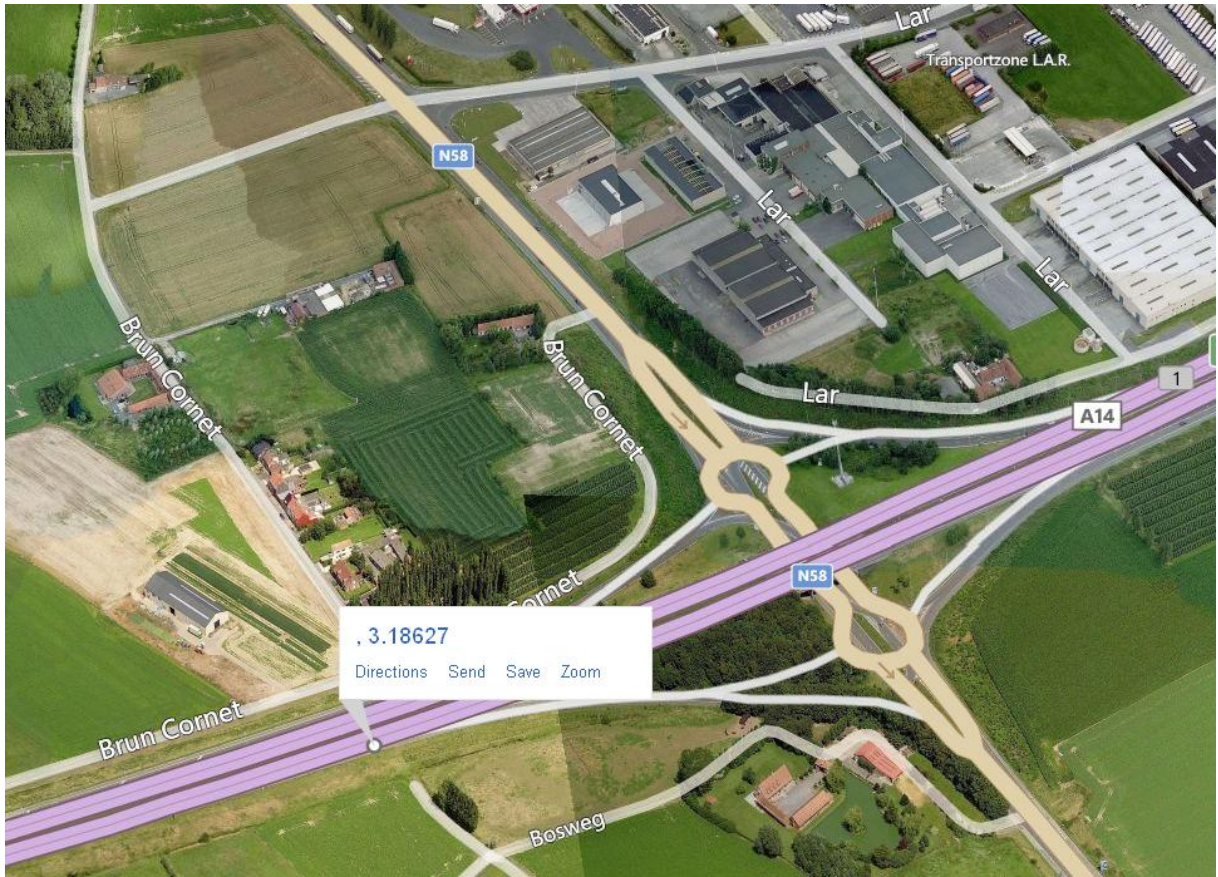

Figure 16 birds eye view.

6.3. ONLINE ANALYZING DATA

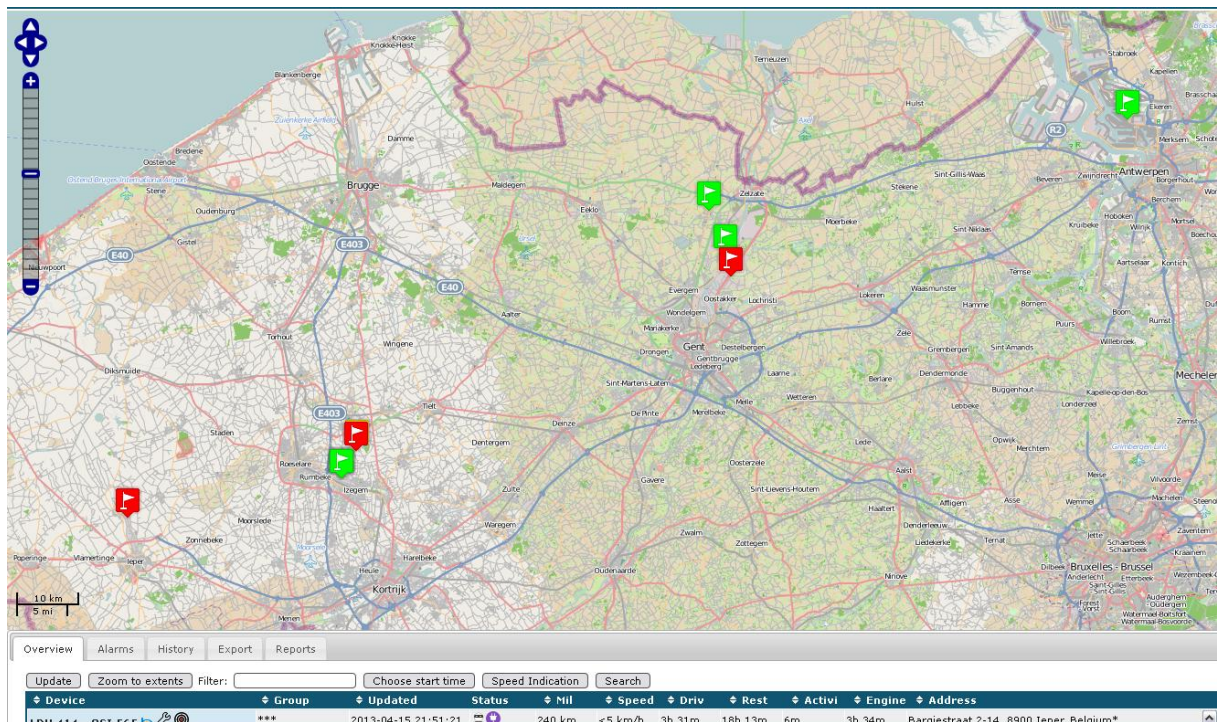

Figure 17 all units

in the table, different numbers can be seen

- Device name
- Device group
- Last time updated
- A status. The icons will be explained further in the text
- Odometer: the total distance driven since the start time²
- The speed at the transmission moment
- The time that the unit was driving
- The time that there was an activity measured by the unit. Activity will be defined further in the text
- Rest time. This is the time that there was no activity and the unit was not driving since the start time
- Address. This is the address out of public databases with the nearest address at the measured position

² The start time is defined with the button “start time”

In the table the driven distances and timings are given. With the button “choose start time”, the start time of these statistics is given.

With the button “search” it is possible to find the unit nearest to a position.

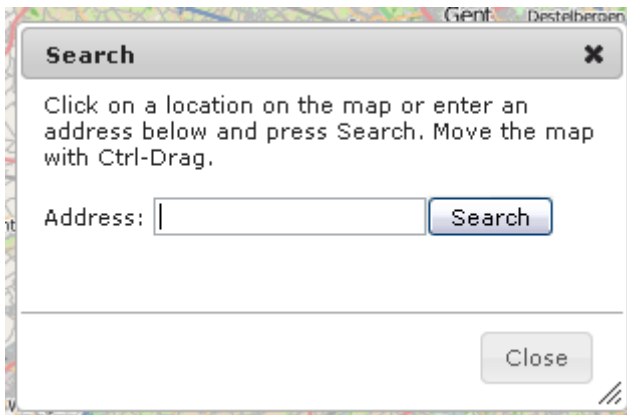

Figure 18 search menu

Or an address can be given (at whatever level) or a point on the map can be clicked.

A circle shows the position of the nearest unit. Its name is given in the menu.

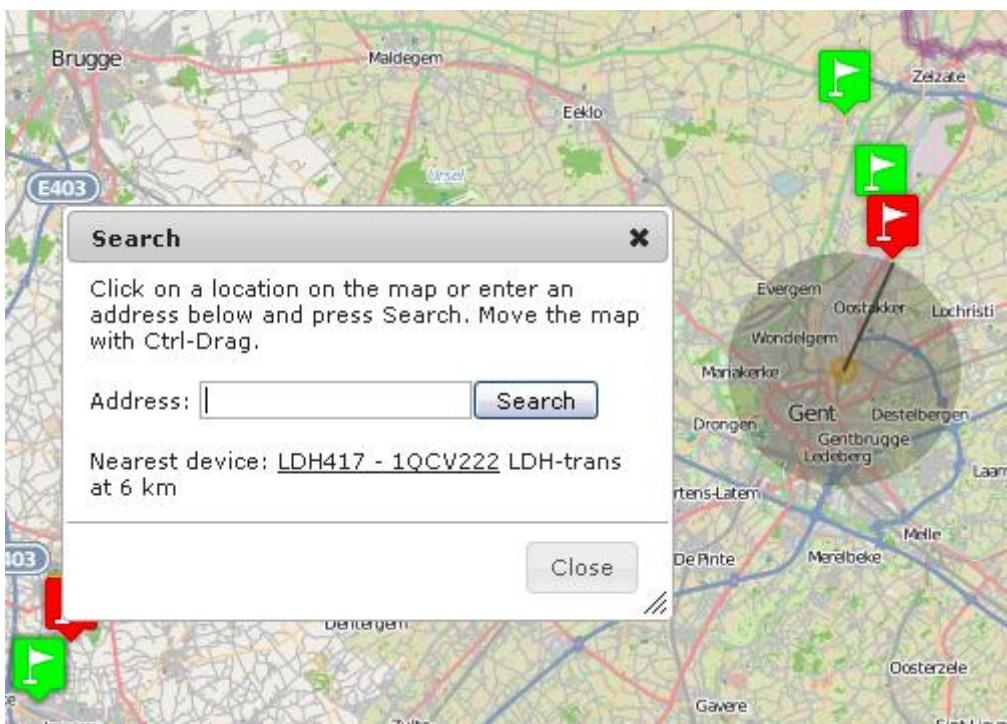

Figure 19 search result

With the button “speed indication” it is possible to change the indicated speed between the average speed between 2 points or the maximum speed. This setting is used in the overview and in the history.

Speed indication:

- Average speed (default)
- Maximum speed

ok



Figure 20 speed selection menu

6.3.1. THE HISTORY OF A UNIT

The 3rd tab gives the possibility to see the history of a unit between 2 times (date and hour).

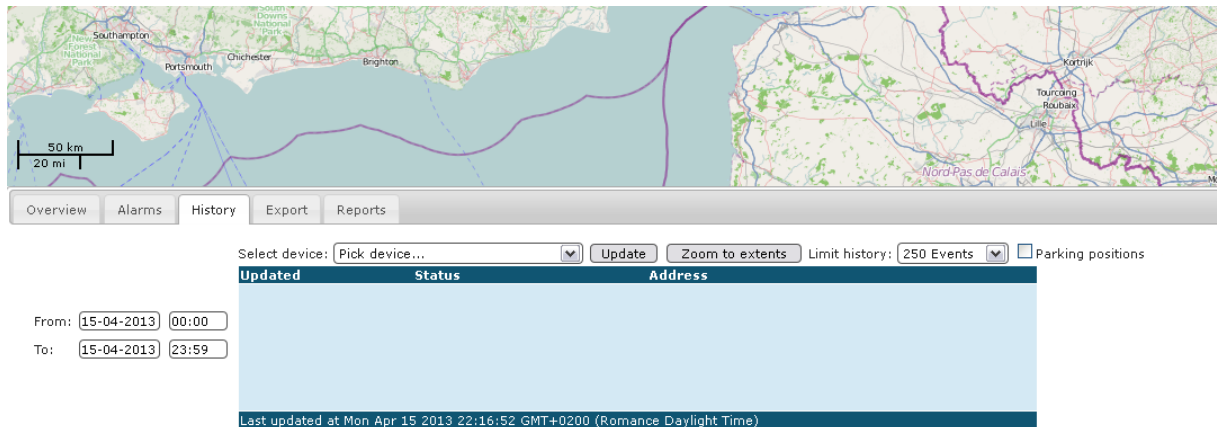
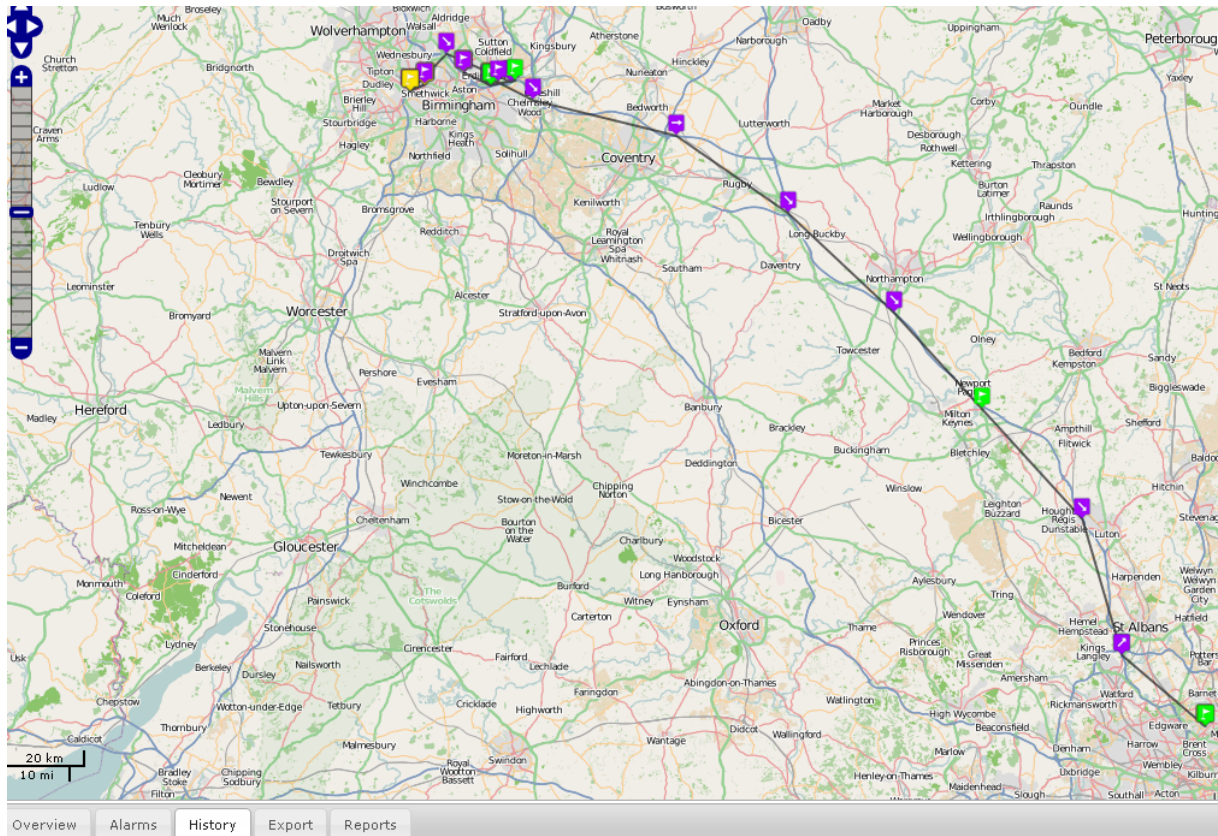

Figure 21 history selection

To select the history of a unit the start date and time and the end date and time have to be selected.

The unit name also has to be selected.

It is possible to change the number of events shown. This is the number from now, counting back to the past. Standard it put at 250 events. This can be increased for long time periods, but this will also influence the update time of the screen.



Select device: 0333 universal demo unit Limit history: 250 Events Parking positions

Updated	Status	Address
From: <input type="text" value="15-04-2013"/> <input type="text" value="00:00"/>		
To: <input type="text" value="15-04-2013"/> <input type="text" value="23:59"/>		
2013-04-15 21:36:32		241 km [<5 km/h] POI b.Alert UK, Nether Street, West Finchley, London Borough of Barnet, London, Greater London, England, N3 1L United Kingdom*
2013-04-15 21:34:53		241 km [<5 km/h] POI b.Alert UK, Nether Street, West Finchley, London Borough of Barnet, London, Greater London, England, N3 1L United Kingdom*
2013-04-15 21:33:53		241 km [5 km/h] POI b.Alert UK, Nether Street, West Finchley, London Borough of Barnet, London, Greater London, England, N3 1L
Last updated at Mon Apr 15 2013 22:18:05 GMT+0200 (Romance Daylight Time)		

Figure 22 history of a unit

The distance shown is the distance driven between the begin and the end time.

The arrows are shown when the units drives at a speed higher than 25 km/h. They indicate the driving direction.

The button “parking positions” gives only the positions where the unit has been parked.

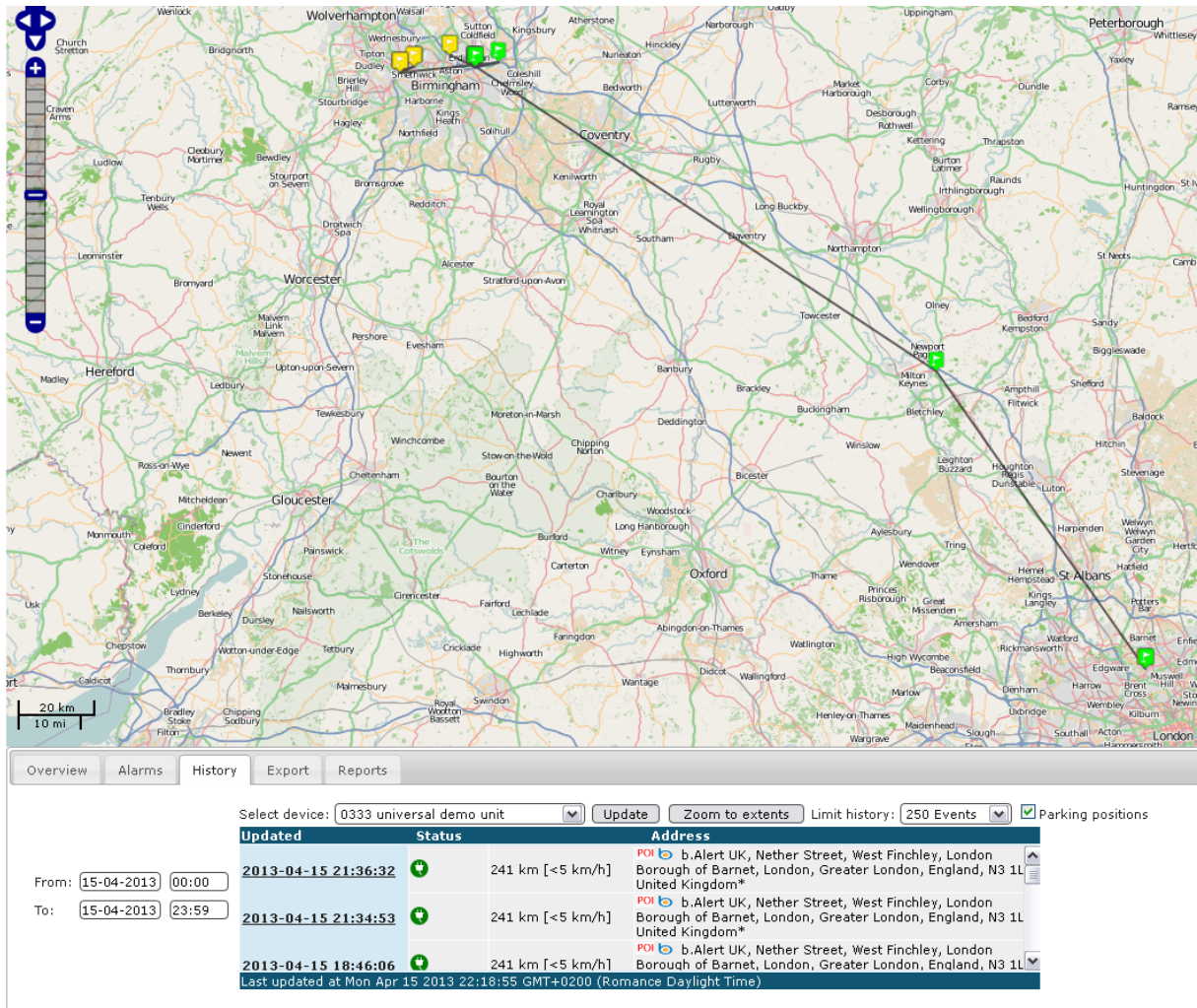

Figure 23 parking positions

To change between the parking positions and all positions, the button “update” needs to be pressed after the selection to the right of the screen.

On top of the screen, there is a button “show/hide map”.

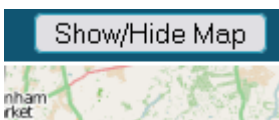

Figure 24 show/hide map

Pushing this button removes the map and shows only table view³.

³ The same effect as Overview screen

Select device: 0333 universal demo unit Limit history: 250 Events Parking positions

Updated	Status	Address
2013-04-15 21:36:32		241 km [<5 km/h] POI b.Alert UK, Nether Street, West Finchley, London Borough of Barnet, London, Greater London, England, N3 1L United Kingdom*
2013-04-15 21:34:53		241 km [<5 km/h] POI b.Alert UK, Nether Street, West Finchley, London Borough of Barnet, London, Greater London, England, N3 1L United Kingdom*
2013-04-15 18:46:06		241 km [<5 km/h] POI b.Alert UK, Nether Street, West Finchley, London Borough of Barnet, London, Greater London, England, N3 1L United Kingdom*
2013-04-15 18:45:47		241 km [<5 km/h] POI b.Alert UK, Nether Street, West Finchley, London Borough of Barnet, London, Greater London, England, N3 1L United Kingdom*
2013-04-15 18:34:12		241 km [<5 km/h] POI b.Alert UK, Nether Street, West Finchley, London Borough of Barnet, London, Greater London, England, N3 1L United Kingdom*
2013-04-15 17:26:25		169 km [<5 km/h] POI Portway, Pineham, Milton Keynes Village, Milton Keynes, South East England, England, United Kingdom**
2013-04-15 16:06:55		67 km [<5 km/h] POI Fort Shopping Centre, adj Fort Shopping Centre, Bromford, Birmingham, West Midlands B24, UK*
2013-04-15 16:05:26		67 km [<5 km/h] POI Fort Shopping Centre, adj Fort Shopping Centre, Bromford, Birmingham, West Midlands B24, UK*
2013-04-15 15:57:42		67 km [<5 km/h] POI Fort Parkway, Castle Vale, Birmingham, West Midlands England, B24, United Kingdom*
2013-04-15 15:02:55		67 km [<5 km/h] POI Fort Parkway, Castle Vale, Birmingham, West Midlands England, B24, United Kingdom*
2013-04-15 14:35:54		60 km [<5 km/h] POI Perrywell Road, Birmingham, West Midlands B6, UK*
2013-04-15 14:35:22		60 km [<5 km/h] POI Perrywell Road, Birmingham, West Midlands B6, UK*
2013-04-15 14:18:29		60 km [<5 km/h] POI Perrywell Road, Birmingham, West Midlands B6, UK*
2013-04-15 13:55:40		53 km [<5 km/h] POI Mothercare, Fort Parkway, Castle Vale, Birmingham, West Midlands, England, B24, United Kingdom*
2013-04-15 13:47:13		52 km [<5 km/h] POI Republic, Fort Parkway, Castle Vale, Birmingham, West Midlands, England, B24, United Kingdom**
2013-04-15 13:42:22		52 km [<5 km/h] POI Marks & Spencer, Fort Parkway, Castle Vale, Birmingham, West Midlands, England, B24, United Kingdom*
2013-04-15 13:37:31		52 km [<5 km/h] POI Republic, Fort Parkway, Castle Vale, Birmingham, West Midlands, England, B24, United Kingdom**
2013-04-15 13:32:40		52 km [<5 km/h] POI Carphone Warehouse, Fort Parkway, Castle Vale, Birmingham, West Midlands, England, B24, United Kingdom*
2013-04-15 13:29:48		52 km [<5 km/h] POI Carphone Warehouse, Fort Parkway, Castle Vale, Birmingham, West Midlands, England, B24, United Kingdom*
2013-04-15 13:27:49		52 km [<5 km/h] POI Fort Parkway, Castle Vale, Birmingham, West Midlands England, B24, United Kingdom*
2013-04-15 13:27:16		52 km [<5 km/h] POI Fort Parkway, Castle Vale, Birmingham, West Midlands England, B24, United Kingdom*
2013-04-15 13:20:06		52 km [<5 km/h] POI Fort Parkway, Castle Vale, Birmingham, West Midlands England, B24, United Kingdom*
2013-04-15 13:00:12		35 km [<5 km/h] POI M6, Solihull, West Midlands, England, B76 9, United Kingdom*
2013-04-15 11:50:55		7 km [<5 km/h] POI Wellington Street, Birchfield, Sandwell, West Midlands England, B69 4NH, United Kingdom*
		POI Albert Street East, Birchfield, Sandwell, West Midlands

From: 15-04-2013 00:00
To: 15-04-2013 23:59

Last updated at Mon Apr 15 2013 22:20:55 GMT+0200 (Romance Daylight Time)

Figure 25 show/hide map results

6.4. ALARMS

6.4.1. NO POWER

It is possible for a unit to be without external power, when the trailer is parked. Once it is driving, it should get power.

In the preferences, it is possible to define a safe zone to drive without power. In this zone, driving without power will give a purple flag and a green icon in the table.

If the unit is driving outside a safe zone without power, this is not allowed, the “plug” in the table turns red and the flag on the map turns also red.

When the trailer is parked, the plug and the flag turn green.

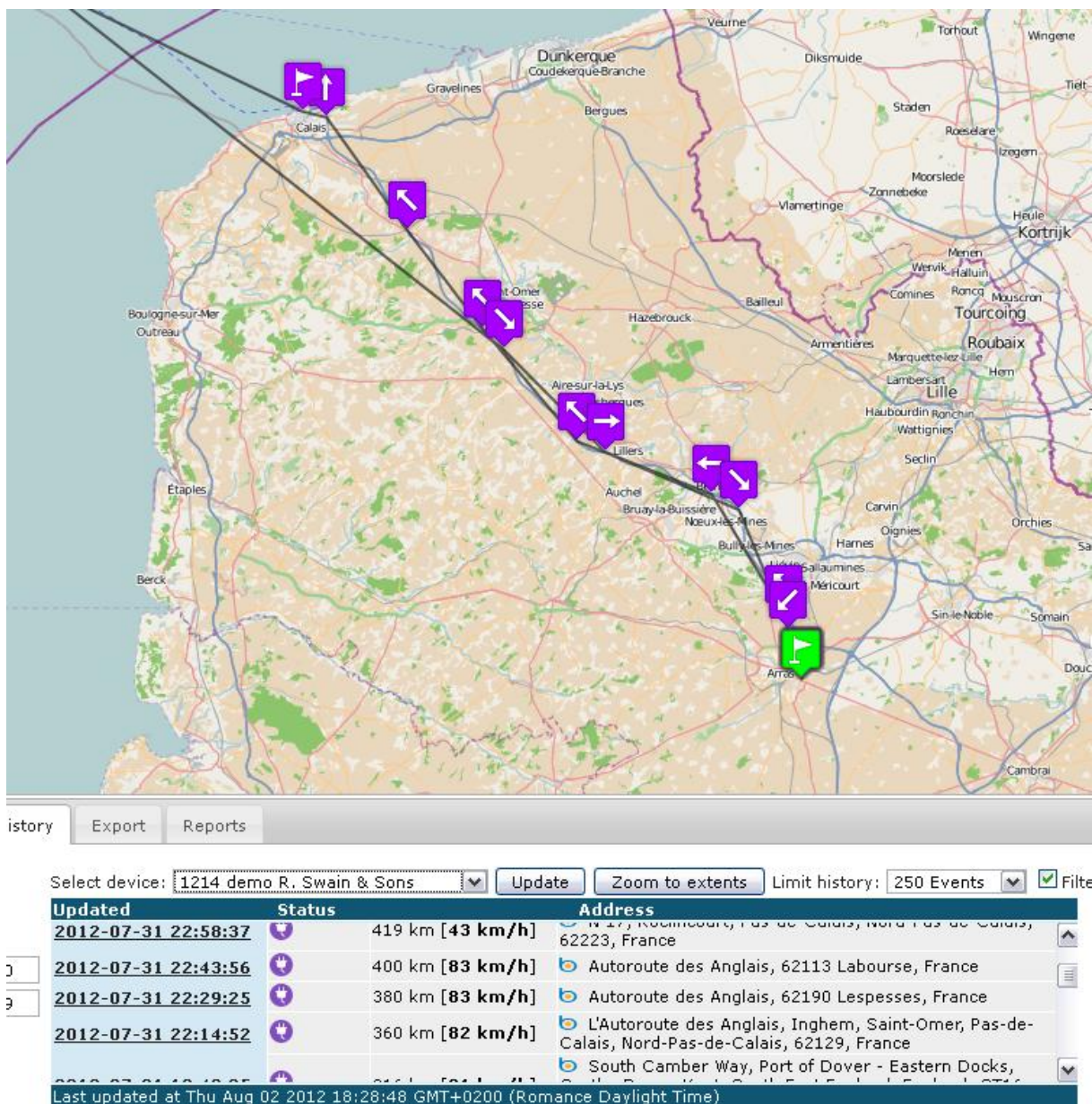

Figure 26 example of driving and parking without power

6.4.2. BATTERY LOW

When the battery is low, the number of transmissions during driving is reduced to keep the possibility to send entries as long as possible.

This situation is indicated with a red flag and a battery sign in the table.

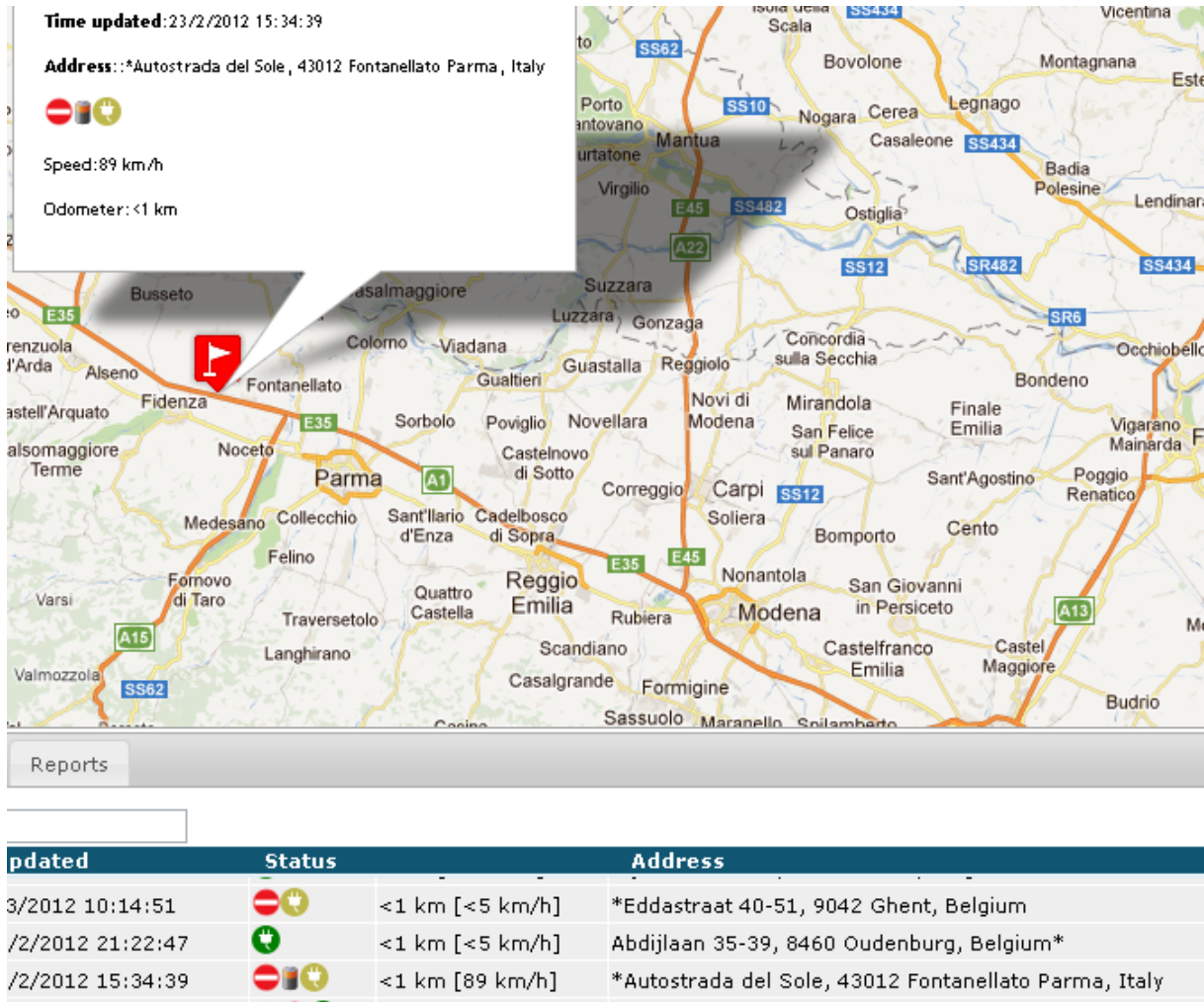

Figure 27 low battery indication

Driving with a low battery is indicated in red, being parked with a low battery also.

6.4.3. FUEL ALARM

There are 2 possible indications for the fuel alarm:

- A real (phase 2) alarm for a real break in: a red status symbol



Figure 28 real fuel alert

- An indication of an important vibration, probably a break in or something important on the fuel tank caused by a human, **with the unit deactivated by the driver**. This can in principle only exist when refueling or with maintenance on the truck : an orange symbol



Figure 29 deactivated fuel alert

6.5. PREFERENCES

6.5.1. USER INFO

▼ User info

Login: demo
Customer number:108
Name : demo
Email address:
SMS:
Time zone: Europe/Brussels ▼
Unit: Metric ▼

New password:
Confirm new password:

▶ Website preferences
▶ Device groups
▶ Devices
▶ Tracking preferences
▶ Maintenance preferences
▶ Geo-fences

Figure 30 user info

This is an informational screen about the user. It gives his name, email address, mobile phone.

It is also possible to choose the time zone or to change the units. At last the password can be changed.

Asia/Istanbul
Europe/Amsterdam
Europe/Berlin
Europe/Brussels
Europe/London
Europe/Paris

Figure 31 available time zones

Unit: Metric ▼
Metric
Imperial

Figure 32 available units

The login, the user name and the customer number cannot be changed.

When a setup has been changed, it is always necessary to push the appropriate “update” button.

6.5.2. WEBSITE PREFERENCES



▼ Website preferences

Update interval:

Language: ▼

Figure 33 website preferences

The website can work in different languages.

The website will automatically update the information on the screen. The update interval can be chosen in seconds. In between, it is always possible to use the different update buttons.

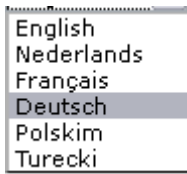

Figure 34 available languages

6.5.3. DEVICE GROUPS

▼ Device groups

Add group

Id	Name	
7	car	✘
8	trailer	

Figure 35 device groups

An unlimited number of groups can be defined for the units. These groups are only used for the maintenance alerts; for the TPMS and for viewing and sorting on the overview.

Setups can be defined per group of units. This is described in detail in **Error! Reference source not found.**

6.5.4. DEVICES

▼ Devices





Id	Name	Group	Enabled	Device specific settings	
1211	Van Hoof 1211	trailer	1	No	
1205	Test Serge 1205	car	1	No	
1201	Test Serge 1201	car	1	No	
1217	hoi 1217	trailer	1	No	
1219	hoi auto vincent 1219	car	1	No	

Figure 36 devices of specific account

A list of devices is given. If needed they can be deactivated. With the key symbol, the setting for a unit can be changed.

The settings can be defined for every individual unit. A detailed description is given in **Error! Reference source not found.**

6.5.5. LIMITED USERS

Every administrative user can create limited users. These users get a personal login.

Login of user to create:	<input type="text" value="myNewUser"/>
Initial password:	<input type="text" value="password"/>
Name of user to create:	<input type="text" value="Name of user"/>
Email address:	<input type="text"/>
SMS number:	<input type="text"/>
User can view devices:	<input type="checkbox"/>
User can perform maintenance tasks:	<input type="checkbox"/>
User can couple to devices:	<input type="checkbox"/>
User can change private/business usage:	<input type="checkbox"/>
User can temporary disable entry alarm:	<input type="checkbox"/>
<input type="button" value="Add user"/>	

Figure 37 creation of limited users

The administrative user defines the rights of the limited user.

Devices

With the button  , the administrative user assigns units to a limited user. Units can be defined to different limited users.

▼ Assigned devices

Login	Device	
vincent	1209 hoi auto demo	<input type="checkbox"/>
vincent	1376 demo basic	<input type="checkbox"/>
vincent	1332 demo basic 1 hour	<input type="checkbox"/>
vincent	1509 demo Container Guy	<input type="checkbox"/>
vincent	1400 demo basic plus	<input type="checkbox"/>

Figure 38 assigned devices to a limited user

A limited user will only see the units assigned to him.

6.5.6. MAILING OF REPORTS

▼ Mail Reports

Add report to be mailed

Name	Time span of report	Frequency	Send at	Format	
Park report sorted by address limited to POI	Since last report	Daily	11 h	HTML	<input type="checkbox"/>
Day summary report	Since midnight day before	Daily	11 h	HTML	<input type="checkbox"/>
Day report	Since midnight Monday	On weekdays	3 h	HTML	<input type="checkbox"/>
Day report	Since midnight first of month	Daily	11 h	HTML	<input type="checkbox"/>
Day summary report	Since last report	Daily	14 h	Excel	<input type="checkbox"/>
Activity report	Since last report	Daily	0 h	HTML	<input type="checkbox"/>

Update preferences

Figure 39 mailing of reports

All of the report types can be configured for defined time periods and emailed out at defined timings to the email address of the login user.

The menu defines the type of report, the time span covered by the report, the frequency of sending, the exact time of sending and the format.

7. FIGURES AND TABLES

Figure 1 b.Alert Fuel v2 sensor installed on tank	7
Figure 2 inside of main unit.....	8
Figure 3 cable connections on main unit	9
Figure 4 cabel connections main unit : scheme	9
Figure 5 electrical connections b.Alert Fuel V2.....	10
Figure 6 login screen	14
Figure 7 basic screen	15
Figure 8 settings	16
Figure 9 map	17
Figure 10 lists	18
Figure 11 Choose start time	18
Figure 12 tabs.....	19
Figure 13 unit to demonstrate Bing	20
Figure 14 aerial map of bing.....	21
Figure 15 choose bird's eye view	21
Figure 16 birds eye view.....	22
Figure 17 all units	23
Figure 18 search menu.....	24
Figure 19 search result	24
Figure 20 speed selection menu	25
Figure 21 history selection	26
Figure 22 history of a unit	27
Figure 23 parking positions	28
Figure 24 show/hide map	28
Figure 25 show/hide map results.....	29
Figure 26 example of driving and parking without power	30
Figure 27 low battery indication	31

Figure 28 real fuel alert 32

Figure 29 deactivated fuel alert 32

Figure 30 user info 33

Figure 31 available time zones 33

Figure 32 available units 33

Figure 33 website preferences 35

Figure 34 available languages 35

Figure 35 device groups 36

Figure 36 devices of specific account 37

Figure 37 creation of limited users 38

Figure 38 assigned devices to a limited user 38

Figure 39 mailing of reports 39

COPYRIGHT NOTICE

All rights reserved. No part of this publication may be reproduced, stored in a retrieval system, or transmitted, in any form or by any means, electronic, mechanical, photocopying, recording or otherwise, without the written permission of b.Alert, Cassandra NV, St Jansstraat 15, 8000 Brugge, Belgium.

This instruction manual and the products described in this instruction manual may be, include or describe copyrighted material, such as computer programs stored in semiconductor memories or other media. Laws in Europe and other countries preserve for Cassandra NV, b.Alert and its licensors certain exclusive rights for copyrighted material, including the exclusive right to copy, reproduce in any form, distribute and make derivative works of the copyrighted material. Accordingly, any copyrighted material in the products described in this instruction manual may not be copied, reproduced, distributed, merged or modified in any manner. Furthermore, the purchase of these products shall not be deemed to grant either directly or by implication or otherwise, any license under the copyrights, patents or patent applications, as arises by operation of law in the sale of a product.

PRELIMINARY NOTICE

Kassandra NV aims to deliver hard- software of high quality which conforms to the specifications agreed with licensees, but cannot guarantee that all features will perform exactly as described. Those who use the program do so on the understanding that the results from analysis software are dependent on the inputs and on the quality of the communication networks where the hardware is used. Kassandra NV has no influence on the quality of the network communication and cannot be responsible for the consequences of the network quality. In any case, the program should be used in accordance with the instructions contained in this documentation and other information provided with the program or otherwise supplied by Kassandra NV. Kassandra NV does not warrant that any specific feature will produce specific results, and does not accept liability for any losses, direct, consequential or otherwise, resulting from the use of the hard- or software.

While reasonable efforts have been made to assure the accuracy of this document, Kassandra NV assumes no liability resulting from any inaccuracies or omissions in this document, or from use of the information obtained herein. The information in this document has been carefully checked and is believed to be entirely reliable. However, no responsibility is assumed for inaccuracies or omissions. Kassandra NV reserves the right to make changes to any products described herein and reserves the right to revise this document and to make changes from time to time in content hereof with no obligation to notify any person of revisions or changes. Kassandra NV does not assume any liability arising out of the application or use of any product, software, or circuit described herein; neither does it convey license under its patent rights or the rights of others. It is possible that this publication may contain references to, or information about Kassandra products (machines and programs), programming, or services that are not announced in your country. Such references or information must not be construed to mean that Kassandra NV intends to announce such products, programming, or services in your country.

REGULATIONS



All hardware complies with CE, EMC and low voltage directives of the EU. It needs to be correctly installed on a compatible host system.

The modules have been assessed in order to satisfy the essential requirements of the R&TTE Directive 1999/05/EC (Radio Equipment & Telecommunications Terminal Equipments) to demonstrate the conformity against the harmonized standards with the final involvement of a Notified Body.

The modules are in compliance with the essential requirements and other relevant provisions of the directives 2006/95/EC (LVD), 2011/65/EU (RoHS) and 2004/104/EC (EMC).

BATTERY DISPOSAL

Risk of explosion if the battery is replaced with an incorrect type. Batteries should be recycled where possible. Disposal of used batteries must be in accordance with local environmental regulations.

HIGH RISK MATERIALS

Components, units, or third-party products used in the product described herein are NOT fault-tolerant and are NOT designed, manufactured, or intended for use as on-line control equipment in the following non limited list of hazardous environments requiring fail-safe controls: the operation of Nuclear Facilities, Aircraft Navigation or Aircraft Communication Systems, Air Traffic Control, Life Support, or Weapons Systems (High Risk Activities”). B.Alert and its supplier(s) specifically disclaim any expressed or implied warranty of fitness for such High Risk Activities.

ENVIRONMENTAL INFORMATION FOR CUSTOMERS IN THE EUROPEAN UNION



European Directive 2002/96/EC requires that the equipment bearing this symbol on the product and/or its packaging must not be disposed of with unsorted municipal waste. The symbol indicates that this product should be disposed of separately from regular household waste streams. It is your responsibility to dispose of this and other electric and electronic equipment via designated collection facilities appointed by the government or local authorities. Correct disposal and recycling will help prevent potential negative consequences to the environment and human health. For more

detailed information about the disposal of your old equipment, please contact your local authorities, waste disposal service, or the shop where you purchased the product.



Recupel membership 491611.



LIMITED PRODUCT WARRANTY

GENERAL TERMS

This Limited Product Warranty applies to B.ALERT branded products (collectively referred to as "B.ALERT Products") sold by Cassandra NV., its European subsidiaries, affiliates, authorized resellers, or country distributors (collectively referred to as "B.ALERT Resellers") with this Limited Product Warranty. The term "B.ALERT Product" is limited to the hardware components and all its internal components including firmware and the balert.net platform. The term "B.ALERT Product" DOES NOT include any other software applications or programs. This Limited Product Warranty is only effective upon presentation of the proof of purchase. Upon further request by B.ALERT, this warranty card has to be presented, too.

Except as expressly set forth in this limited warranty, b.Alert makes no other warranties, express or implied, including any implied warranties of merchantability and fitness for a particular purpose. B.Alert expressly disclaims all warranties not stated in this limited warranty any implied warranties that may be imposed by law are limited in duration to the limited warranty period.

To the extent allowed by local law, the remedies in this warranty statement are client's sole and exclusive remedies against b.Alert. In no event will b.Alert be liable for loss of data or for indirect, special, incidental, consequential (including lost profit or data), or other damage, whether based in contract, tort, or otherwise.

COUNTRIES IN WHICH THIS B.ALERT LIMITED PRODUCT WARRANTY APPLIES

This Limited Product Warranty is applicable to Hardware Products sold by B.Alert Resellers in all countries listed under the heading "Countries in which this B.ALERT Limited Product Warranty applies". The Limited Product Warranty will be honored in any country where B.ALERT or its authorized service providers offer warranty service subject to the terms and conditions set forth in this Limited Product Warranty. However, warranty service availability and response times may vary from country to country and may also be subject to registration requirements.

LIMITATION OF PRODUCT WARRANTY

B.ALERT warrants that the products described below under normal use are free from material defects in materials and workmanship during the Limited Product Warranty Period set forth below ("Limited Product Warranty Period"), if the product is used and serviced in accordance with the user manual and other documentation provided to the purchaser at the time of purchase (or as amended from time to time).

B.ALERT does not warrant that the products will operate uninterrupted or error-free or that all deficiencies, errors, defects or non-conformities will be corrected.

This warranty shall not apply to problems resulting from: (a) unauthorized alterations or attachments; (b) negligence, abuse or misuse, including failure to operate the product in accordance with specifications or interface requirements; (c) improper handling; (d) failure of goods or services not obtained from B.ALERT or not subject to a then-effective B.ALERT warranty or maintenance agreement, (e) improper use or

storage, (f) opening or removing Covers or (g) fire, water, acts of God or other catastrophic events. This warranty shall also not apply to any particular product where the B.ALERT serial number has been removed or defaced in any way b.Alert is not responsible for damage that occurs as a result of your failure to follow the instructions for b.Alert

LIMITED PRODUCT WARRANTY PERIOD

The Limited Product Warranty Period starts on the date of purchase from B.ALERT. Your dated sales or delivery receipt, showing the date of purchase of the product, is your proof of the purchase date. You may be required to provide proof of purchase as a condition of receiving warranty service. You are entitled to warranty service according to the terms and conditions of this document if a repair to your B.ALERT branded hardware is required within the Limited Product Warranty Period.

This Limited Product Warranty extends only to the original end user purchaser of this B.ALERT Product and is not transferable to anyone who obtains ownership of the B.ALERT Hardware Product from the original end-user purchaser.

Warranty Period: Two (2) years.

LIMITED PRODUCT WARRANTY PERIOD

If a product defect occurs, B.ALERT 's sole obligation shall be to repair or replace any defective B.Alert Product free of charge provided it is returned to an Authorized B.ALERT Service Centre during the Limited Warranty Period. Such repair or replacement will be rendered by B.ALERT at an Authorized B.ALERT Service Centre. All component parts or hardware products that are replaced under this Limited Product Warranty become the property of B.ALERT. The replacement part or product takes on the remaining Limited Warranty Period of the replaced part or product. The replacement product need not be new or of an identical make, model or part; B.ALERT may in its discretion replace the defective product (or any part thereof) with any reconditioned equivalent (or superior) product in all material respects to the defective product.

WARRANTOR

Kassandra NV.

Telephone +32 (0)50 47 20 23

Spanjaardstraat 4

8000 Brugge

Belgium

SAFETY INSTRUCTIONS

Please adhere to the following safety guidelines to help ensure your own personal safety and protect your system from potential damage. Any acts taken that are inconsistent with ordinary use of the product, including improper testing, etc, and those not expressly approved by B.Alert may result in the loss of product warranty.

Unless expressly approved by an authorized representative of B.Alert in writing, you may not and may not permit others to,

- Disassemble or reverse engineer the device or attempt to derive source code (underlying ideas, algorithms, or structure) from the device or from any other information provided by b.Alert. except to the extent that this restriction is expressly prohibited by local law.
- Modify or alter the device.
- Remove from the device any product identification or other notices, including copyright notices and patent markings, if any.

To reduce the risk of bodily injury, electrical shock, fire, and damage to the device and other equipment, observe the following precautions:

POWER SOURCES

- Observe and follow service markings.
- Do not push any objects into the openings of your device unless consistent with the authorized operation of the device. Doing so can cause a fire or an electrical shock by shorting out interior components.
- The powering of this device must adhere to the power specifications indicated for this product.
- Do not overload extension cords as this will increase the risk of fire or electrical shock.
- Do not rest anything on the power cord or on the device (unless the device is made and expressly approved as suitable for stacking).
- Position system cables and power cables carefully; route cables so that they cannot be stepped on or tripped over. Be sure that nothing rests on any cables
- Operate the device only from the type of external power source indicated on the electrical ratings label.
- Use only approved power cable(s). If you have not been provided a power cable for your device or for any AC-powered option intended for your device, purchase a power cable that is approved for use in your country and is suitable for use with your device. The power cable must be rated for the device and for the voltage and current marked on the device's electrical ratings label. The voltage and current rating of the cable should be greater than the ratings marked on the device.
- When connecting or disconnecting power to pluggable power supplies, if offered with your device, observe the following guidelines

- Install the power supply before connecting the power cable to the power supply.
- Unplug the power Cable before removing the power supply,
- If the system has multiple sources of power, disconnect power from the device by unplugging all power cables from the power supplies.

BATTERY

This product uses a LiPo battery. Please charge the battery fully before first use. Refer to operational temperature ranges in the specification appendix. Operation in low (below -20°C) or high (over 45°C) temperatures will affect power supply efficiency and the ability to charge the battery. All Lithium-Ion batteries will experience power supply efficiency deterioration over time, even if not used, and have a limited life expectancy. Do not pierce, open or disassemble the battery Do not swallow the battery. If the battery leaks and you come into contact with the leaked fluids, rinse thoroughly with water and seek medical attention immediately.

Do not put, store or leave your product in or near a heat source; in a high temperature location; in strong direct sunlight; in a microwave oven; in a pressurized container, and do not expose it to temperatures over 80°C. Failure to follow these guidelines may cause the Lithium-Ion battery to leak acid; become hot explode; or ignite and cause injury and/or damage.

The lithium-ion battery contained in the product must be recycled or disposed of properly. Use only with supplied charger(s) and supplied ac adaptor for battery charging.

SERVICING AND DISASSEMBLING

- Do not service any product except as expressly set forth in your system documentation.
- Opening or removing Covers that are marked with the triangular symbol with a lightning bolt may expose you to an electrical shock. Only a trained service technician should service components inside these compartments.
- To reduce the risk of electrical shock, never disassemble this device. None of its internal parts are user-replaceable; therefore, there is no reason to access the interior.
- Do not spill food or liquids on your system components, and never operate the device in a wet environment. If the device gets wet, see the appropriate section in your troubleshooting guide or contact your trained service provider.
- Use the device only with approved equipment

ENVIRONMENT

- Do not immerse the product under water



- Keep your device away from radiators and heat sources. Also, do not block cooling vents.

CLEANING

- Do not use liquid or aerosol cleaners of any kind. Use only compressed air that is recommended for electronic devices.